

Reg. No. :

--	--	--	--	--	--	--	--	--	--	--	--	--	--	--

Question Paper Code : D41103

B.E. / B.Tech. DEGREE EXAMINATIONS, JUNE / JULY 2021

Fourth Semester

Aerospace Engineering

AC8402 – AEROSPACE STRUCTURAL MECHANICS

(Regulation 2017)

Time: Three Hours

Maximum: 100 Marks

Answer ALL questions

PART – A

(10 x 2 = 20 Marks)

1. Why are semimonocoque structures used?
2. Distinguish between Strength and Stiffness.
3. Define Shear Centre and Shear Flow.
4. What is Anticlastic bending?
5. Explain a concept of stiffened panel?
6. List out the buckling modes of a thin walled section.
7. Write the assumptions of plate theory?
8. Define stress resultants.
- 9 .What is the purpose of sandwich structures?
- 10.How does a laminate differ from a lamina?

PART – B

(5 x 13 = 65 Marks)

11. (a) (i) Explain Semimonocoque structure in detail. (8)
 (ii) Define Simple bending and derive the equation of simple bending. (5)

(or)

- (b) Determine the total strain energy of the L – section which is subjected to 1000N load as shown in fig. The cross sectional area of the member is 6cm×12cm. Assume $E = 2 \times 10^7 \text{ N/cm}^2$ and $G = 0.8 \times 10^7 \text{ N/cm}^2$ (13)

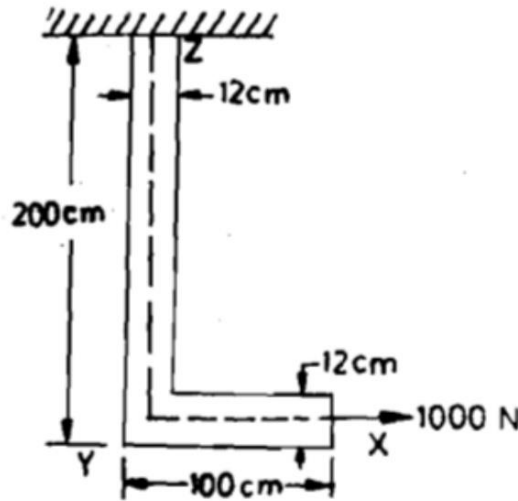

12. (a) A beam having the cross-section shown in Fig. is subjected to a bending moment of 1500 N-m in a vertical plane. Calculate the maximum direct stress due to bending stating the point at which it acts. (13)

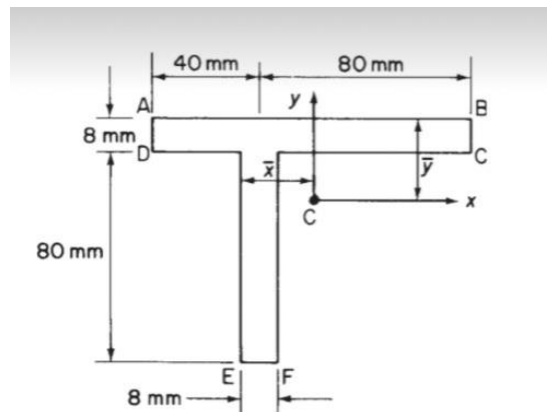

(or)

- (b) (i) A thin-walled circular section beam has a diameter of 200 mm and is 2 m long; it is firmly restrained against rotation at each end. A concentrated torque of 30 kN m is applied to the beam at its mid-span point. If the maximum shear stress in the beam is limited to 200 N/mm² and the maximum angle of twist to 2°, calculate the minimum thickness of the beam walls. Take $G = 25\,000 \text{ N/mm}^2$ (8)
 (ii) Draw and Mark Shear centre for equal section, Z-section, Cruciform, Channel section. (5)

13. (a) (i) A cantilever beam under combined axial and transverse load has $E=10 \times 10^6$ psi, $I=1.33$ in⁴. Then find maximum bending moment M , vertical deflection y , angular deflection of the beam. (8)

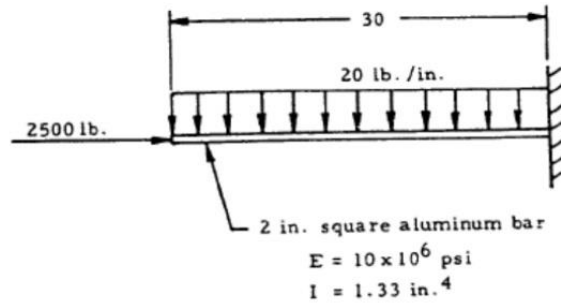

(ii) Write a short notes on inter rivet buckling and sheet wrinkling. (5)

(or)

(b) The sheet stiffened panel consisting of 3 stringers of 25cm long located with 10cm spacing and sheet of 30cm \times 25cm \times 1mm as shown in fig is loaded in compression by means of rigid members. The sheet is assumed to be simply supported at loaded ends and at a rivet lines and to be free at the sides. Each stringers has an area of 50mm². Assume $E = 72.5$ GPa for sheet and stringers. Find the total compressive P , (i) when the sheet first buckles, (ii) when the stringer stress is 70 MPa, (iii) when the stringer stress is 210 MPa. (13)

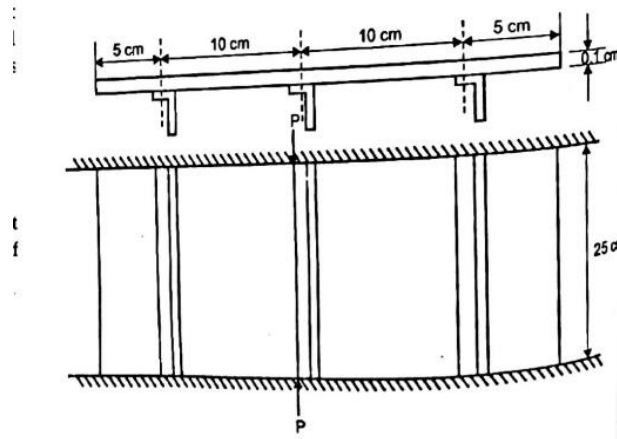

14. (a) Derive the governing equation for thin plate subjected to distributed transverse load. (13)

(or)

(b) (i) Derive the governing equation for bending and twisting of thin plates. (8)

(ii) Show that the deflection function $w = A(x^2y^2 - bx^2y - axy^2 + abxy)$ is valid for a rectangular plate of sides a and b , built in on all four edges and subjected to a uniformly distributed load of intensity q . If the material of the plate has a Young's modulus E and is of thickness t determine the distributions of bending moment along the edges of the plate. (5)

15. (a) (i) Derive the expression for Tsai Hill Failure Criteria. (8)
- (ii) A single sheet of woven ply is subjected to longitudinal and transverse direct stresses of 50 and 25 N/mm², respectively together with a shear stress of 40 N/mm². The elastic constants for the ply are $E_l = 120000$ N/mm², $E_t = 80000$ N/mm², $G_{lt} = 5000$ N/mm² and $\nu_{lt} = 0.3$. Calculate the direct strains in the longitudinal and transverse directions and the shear strain in the ply. (5)

(or)

- (b) Describe sandwich structures Composite with neat sketch and discuss its advantages and applications. (13)

PART – C

(1 x 15 = 15 Marks)

16. (a) A multicell structure shown in fig. subjected to clockwise torque of 1000 N-m. Compute a shear flow in a cell structure and the associated twist. The structure has constant thickness of 3 mm. (15)

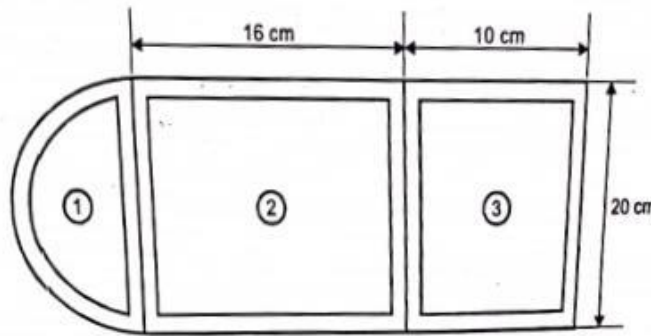

(or)

- (b) Derive the expression for Wagner's tension field beam. (15)